

ZONE	REV	DESCRIPTION	REVISIONS	DATE	APPROVED

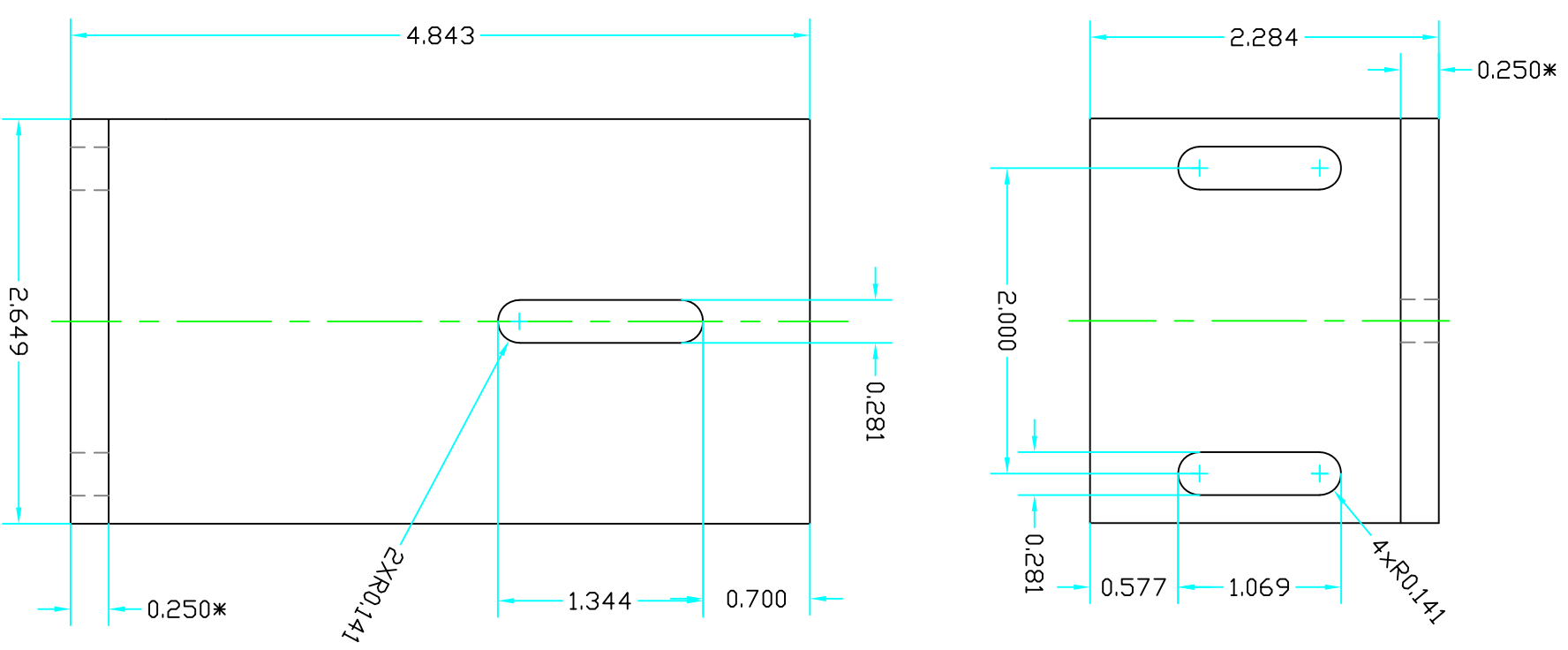
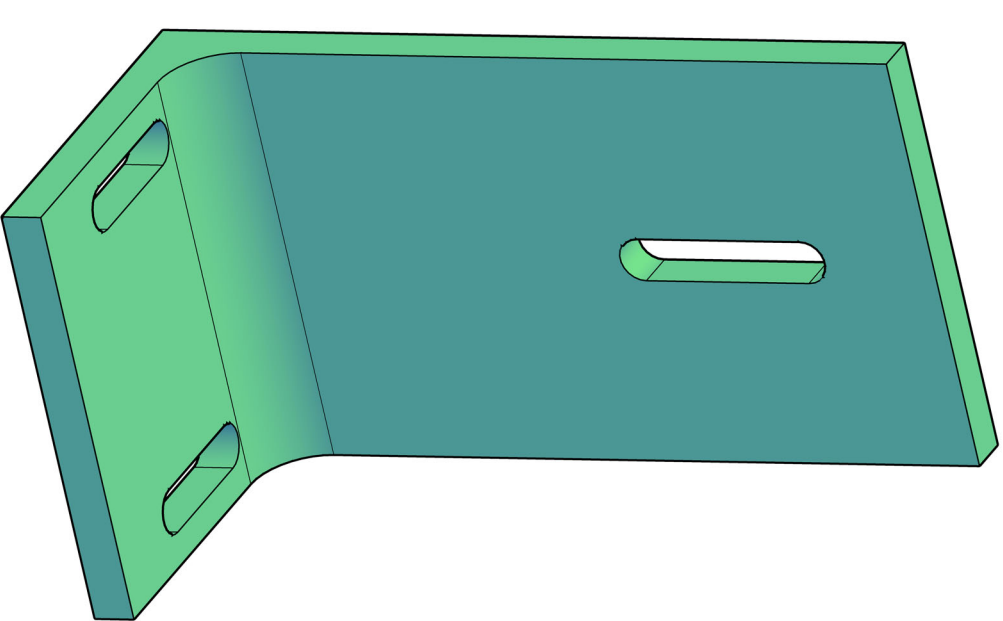

A

B

C

D

6

5

4

3

2

1

A

B

C

D

PART 1	1	EA	SUPPORT	ALUMINUM	PROFILE 5"x3", 1/4" WALL THICKNESS	117.0000
FINU/REF#	QTY.	UM.	PART NAME	MATERIAL	PART DESCRIPTION	REF. SHEET/DWG.
PARTS LIST						
UNLESS OTHERWISE SPECIFIED			PERMISSIBLE VARIATION IN INCH DIMENSIONS WITHOUT TOLERANCES			
1. DIMENSIONS ARE IN INCHES.			FABRICATION TOLERANCES			
2. MACHINE SURFACES TO BE FLAT, SQUARE, PARALLEL & CONCENTRIC BELY 12			MACHINING TOLERANCES			
3. WITHIN .001 FOR 5 INCHES OR .001 TIR AS APPLICABLE.			12 TO 60			
4. MARK ALL DETAILS EXCEPT COMMERCIAL PARTS WITH DWG.			60 TO 180			
5. ITEM NUMBER.			18 TO 48			
6. BREAK ALL SHARP CORNERS .01 x 45° CHAMFER.			OVER 48			
7. FILED'S SHOWN SHARP = 1/4" RADIUS.			ANGLE TOLERANCE 30.1°			
8. CUSTOM BORE, BEAD TOLER 1/16 x 45°.			SURFACE TEXTURE 125			
9. DO NOT SCALE DRAWING.			TOLERANCES ARE NOT ACCUMULATIVE			
10. ALL WELDING TO CONFORM TO LATEST AWS STANDARDS						

REV	DATE	BY	CHKD	APPV	TITLE
1	12/01/22	AD	KH	KH	SRF SUPPORT INNER

Open Source Instruments Inc.

OSI

SIZE	SCALE	DRAWING NUMBER	REVISION
D	1:1	117	A
		117.000.02	1 OF 1